

Unimas



Detailed product information can be found on www.bopla.de



- 4 sizes
- Front panels in various materials
- Optimised for time-saving mounting
- Numerous installation options for PCBs – horizontal and vertical
- Large mounting space for rectangular PCBs

Colour:
Light grey, similar to RAL 7035

Protection class:
IP 40/DIN EN 60529

Enclosure material:
PS (polystyrene); for details see Technical Information

Enclosure with timeless design for universal use



Timeless design and clear styling



Separate front panels for easy processing

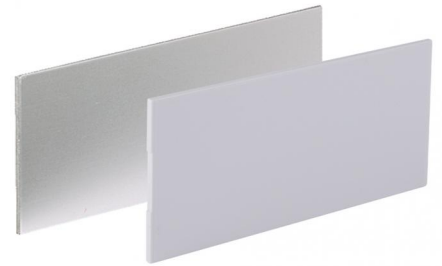

Plastic or aluminium front panels, as requi



Concealed ("invisible") arrangement of screws

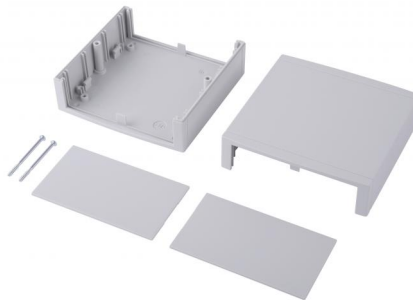

Fast opening and closing with just two screws



Depending on the design, optional screwless latching of the PCBs



PCB mounting in the base and lid

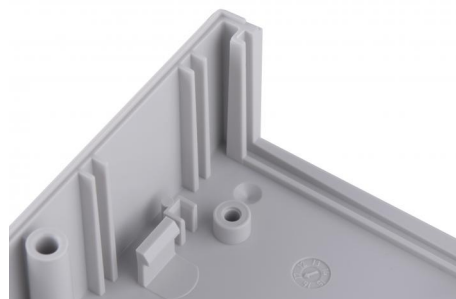

Plug-in options for vertical PCB mounting



Optional rubber feet ensure high level of stability and slip resistance

Unimas | Enclosures



Unimas enclosures

Model	Order no.	A	B	C	a1	a2	b1	c1
U 85-7035	26085000	85	40	81	70,4	79,5	31,4	70,8
U 110-7035	26110000	110	60	107	93,1	104	50,1	95,8
U 135-7035	26135000	135	60	132	118,1	128	50	120,8
U 160-7035	26160000	160	75	133	140,9	152,8	63,8	120,8

Scope of delivery: Lid and base, 2 plastic front panels, 2 screws

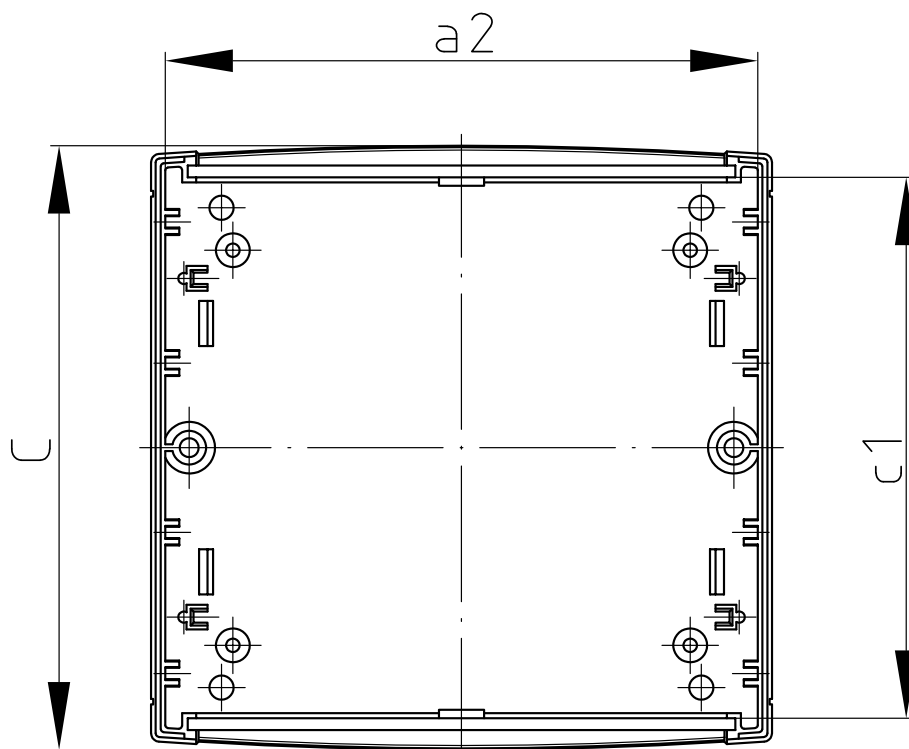
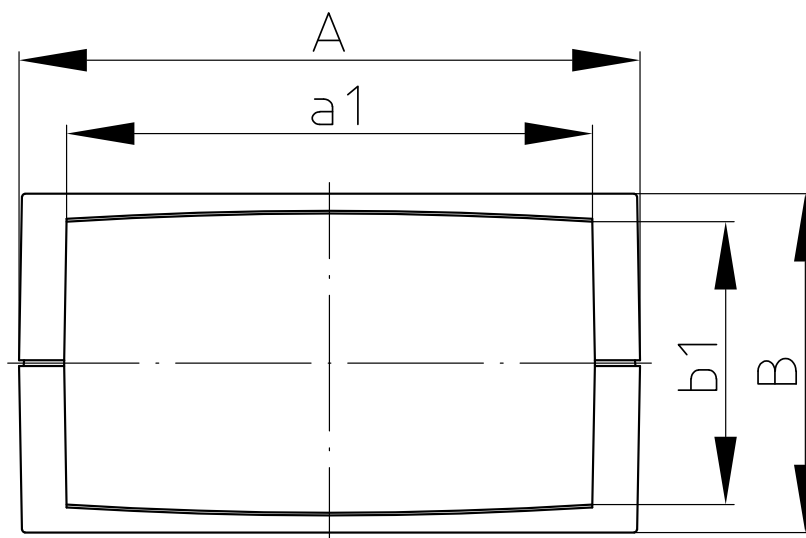

Unimas | Accessories

Front panels, aluminium

Model	Order no.	Note
U 85 FAE	26008500	Für U 85
U 110 FAE	26011000	Für U 110
U 135 FAE	26013500	Für U 135
U 160 FAE	26016000	Für U 160

Scope of delivery: 1 front panel

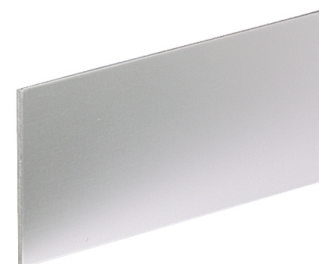

Screw covers

Model	Order no.
U SA-7035	26008000

Scope of delivery: 2 screw covers

Rubber feet

Model	Order no.	Colour	Note
GF	22009000	Black	Polyurethane, 65-75 Shore

Scope of delivery: 4 pieces

