

Euromas Polymas

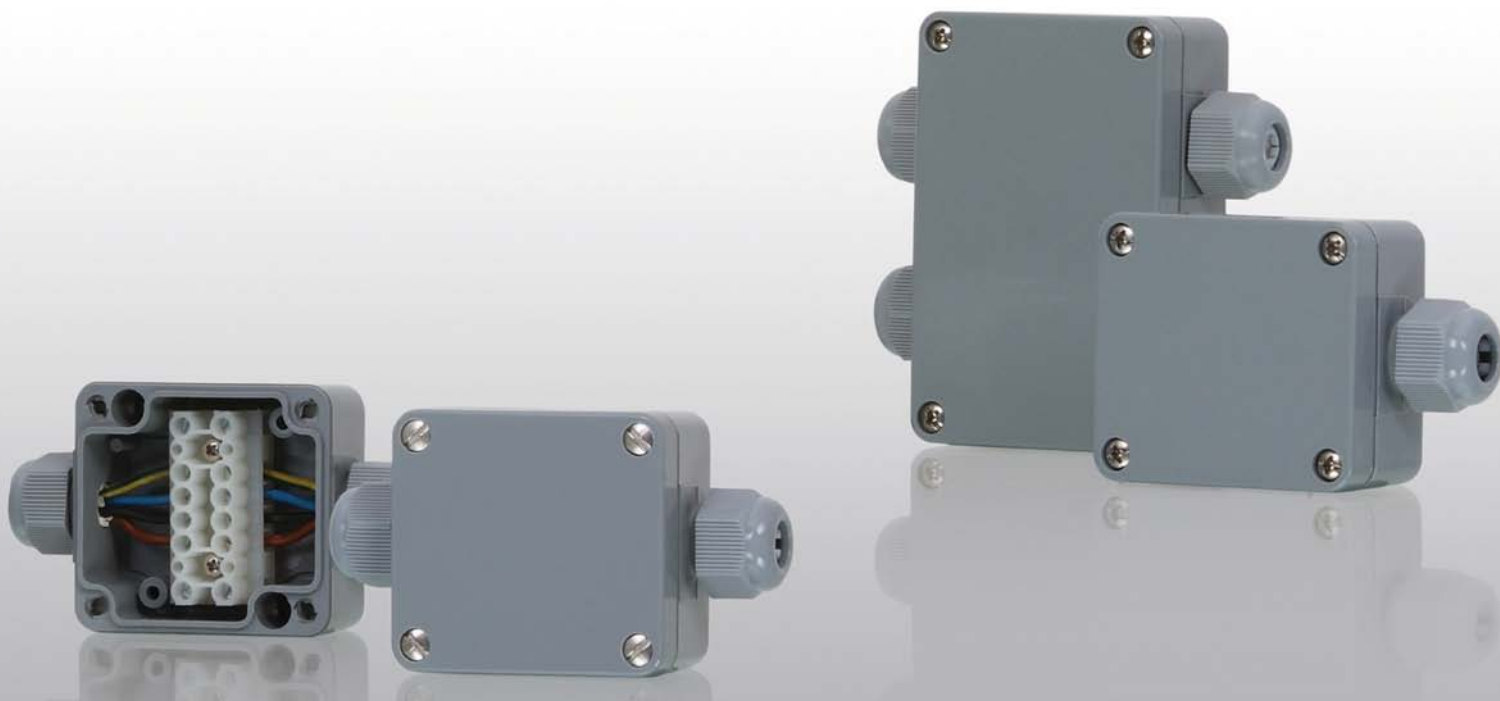

Detailed product information can be found on www.bopla.de



- 5 sizes
- Versions with or without screwing systems
- Quick-release fastener versions
- Transparent lids on request
- Terminals and mounting on request

Colour:

Silver grey, similar to RAL 7001; special colours on request

Protection class:

IP 65/DIN EN 60529; higher ingress protection on request

Enclosure material:

PA 6-GB 30, seal made of CR; for details see Technical Information

The versions of this sturdy polyamide enclosure with moulded-on Pg 11 cable gland reduce processing time and work



PK 101/102/105/110/115: without moulded-on cable gland



PK 101-111: one moulded-on cable gland Pg 11



PK 101-211 / PK 102-211: With two moulded-on PG 11 cable glands.



PK 102-411: four moulded-on cable glands Pg 11



The tension range for moulded-on cable glands is 8-10 mm.



SV version with quick-release fastener



G version with crystal-clear lid on request.

Euromas Polymas | Enclosures



Enclosure

Model	Order no.	A	B	C	a1	a2	b1	b2	c1	c2
PK 101	38101000	58	64	34	51,4	34	57,4	24	9	28,5
PK 101 G	38101020*	58	64	34	51,4	34	57,4	24	9	28,5
PK 102	38102000	98	64	34	91,4	74	57,4	24	9	28,5
PK 102 G	38102020*	98	64	34	91,4	74	57,4	24	9	28,5
PK 105	38105000	75	80	57	66,6	50,6	71,6	39,6	15	51
PK 105 G	38105020*	75	80	57	66,6	50,6	71,6	39,6	15	51
PK 110	38110000	125	80	57	116,6	100,6	71,6	39,6	15	51
PK 110 G	38110020*	125	80	57	116,6	100,6	71,6	39,6	15	51
PK 115	38115000	175	80	57	166,6	150,6	71,6	39,6	15	51
PK 115 G	38115020*	175	80	57	166,6	150,6	71,6	39,6	15	51

Scope of delivery: Lid and base, lid screws made of V2A

Note: G = Model with crystal clear lid.



Enclosure with quick-release fastener

Model	Order no.	A	B	C	a1	a2	b1	b2	c1	c2
PK 101 SV	38101500*	58	64	34	51,4	34	57,4	24	9	28,5
PK 102 SV	38102500*	98	64	34	91,4	74	57,4	24	9	28,5
PK 105 SV	38105500*	75	80	57	66,6	50,6	71,6	39,6	15	51
PK 110 SV	38110500*	125	80	57	116,6	100,6	71,6	39,6	15	51
PK 115 SV	38115500*	175	80	57	166,6	150,6	71,6	39,6	15	51

Scope of delivery: Lid and base, quick-release fastener made of nickel-plated GD-Zn Al4 Cu1



Enclosure with a moulded-on Pg 11

Model	Order no.	A	B	C	a1	a2	b1	b2	b4	c1	c2
PK 101-111	38101100	58	64	34	51,4	34	57,4	24	1	9	28,5
PK 101-111 G	38101120*	58	64	34	51,4	34	57,4	24	1	9	28,5

Scope of delivery: Lid and base, lid screws made of V2A, 1 moulded-on cable gland, Pg 11 including clamping cage, pressure screw and continuous sealing ring

Note: G = Model with crystal clear lid.



Enclosure with quick-release fastener and a moulded-on Pg 11

Model	Order no.	A	B	C	a1	a2	b1	b2	b4	c1	c2
PK 101-111 SV	38101600	58	64	34	51,4	34	57,4	24	1	9	28,5

Scope of delivery: Lid and base, quick-release fastener made of nickel-plated GD-Zn Al4 Cu1, 1 moulded-on cable gland, Pg 11 including clamping cage, pressure screw and continuous sealing ring

Euromas Polymas | Enclosures

Enclosure with 2 moulded-on Pg 11

Model	Order no.	A	B	C	a1	a2	b1	b2	b3	b4	c1	c2
PK 101-211	38101200	58	64	34	51,4	34	57,4	24	1	1	9	28,5
PK 101-211 G	38101220*	58	64	34	51,4	34	57,4	24	1	1	9	28,5
PK 102-211	38102200	98	64	34	91,4	74	57,4	24		2	9	28,5
PK 102-211 G	38102220*	98	64	34	91,4	74	57,4	24		2	9	28,5

Scope of delivery: Lid and base, lid screws made of V2A, 2 moulded-on cable glands, Pg 11 including clamping cage, pressure screw and continuous sealing ring

Note: G = Crystal-clear lid.

Note arrangement of cable glands (see photos at start of chapter).



Enclosure with quick-release fastener and 2 moulded-on Pg 11

Model	Order no.	A	B	C	a1	a2	b1	b2	b3	b4	c1	c2
PK 101-211 SV	38101700	58	64	34	51,4	34	57,4	24	1	1	9	28,5
PK 102-211 SV	38102700	98	64	34	91,4	74	57,4	24		2	9	28,5

Scope of delivery: Lid and base, quick-release fastener made of nickel-plated GD-Zn Al4 Cu1, 2 moulded-on cable glands, Pg 11 including clamping cage, pressure screw and continuous sealing ring

Note: Note arrangement of cable glands (see photos at start of chapter).



Enclosure with 4 moulded-on Pg 11

Model	Order no.	A	B	C	a1	a2	b1	b2	b3	b4	c1	c2
PK 102-411	38102400	98	64	34	91,4	74	57,4	24	2	2	9	28,5
PK 102-411 G	38102420*	98	64	34	91,4	74	57,4	24	2	2	9	28,5

Scope of delivery: Lid and base, lid screws made of V2A, 4 moulded-on cable glands, Pg 11 including clamping cage, pressure screw and continuous sealing ring

Note: G = Model with crystal clear lid.



Enclosure with 4 moulded-on Pg 11

Model	Order no.	A	B	C	a1	a2	b1	b2	b3	b4	c1	c2
PK 102-411 SV	38102900	98	64	34	91,4	74	57,4	24	2	2	9	28,5

Scope of delivery: Lid and base, quick-release fastener made of nickel-plated GD-Zn Al4 Cu1, 4 moulded-on cable glands, Pg 11 including clamping cage, pressure screw and continuous sealing ring

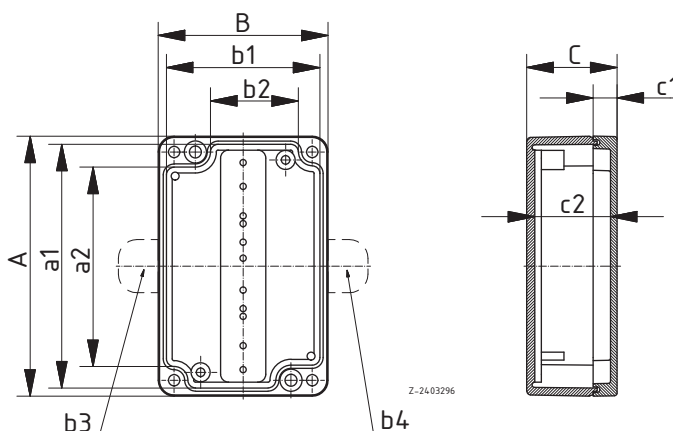

For accessories, please see the end of the chapter

Euromas Polymas | accessories



Silicone seal for lid

Model	Order no.	Note
SIL	21005700	For PK 101, PK 101-111, PK 101-211
SIL	21005800	For PK 102, PK 102-211, PK 102-411
SIL	21006000	For PK 105
SIL	21006100	For PK 110
SIL	21006200	For PK 115

Scope of delivery: 1 seal



Mounting panels for PK 105 - 115, galvanised sheet steel

Model	Order no.	Note
M	21001100	For A 105, PK 105
M	21001200	For A 110, PK 110
M	21001300	For A 115, PK 115

Scope of delivery: 1 mounting panel



DIN rails for PK 105 - 115, DIN EN 60715 TH 15

Model	Order no.	Note
TS 15	21002800*	For A 105, P 305, P 326, PK 105
TS 15	21002900*	For A 110, PK 110
TS 15	21003000*	For A 115, PK 115

Scope of delivery: 1 DIN rail

