

Verwendung der Mastbefestigung für Bocube
Use of the mast attachment for Bocube

Bitte wählen Sie anhand dieser Tabelle je nach Größe und Ausrichtung des Gehäuses die passende Mastbefestigung und den dazugehörigen Befestigungssatz aus.

Please use this table to select the appropriate mast mounting and the associated mounting kit, depending on the size and alignment of the enclosure.

Ausrichtung des Gehäuses / Alignment of the enclosure:

H = horizontal

V = vertical

Gehäuse Enclosure		Mastbefestigung Mast bracket		Befestigungssatz Mounting kit
B 080805 H	=	MH 080	+	BFS MH 1
B 080805 V	=	MH 080	+	BFS MH 1
B 100804 H	=	MH 122	+	BFS MH 1
B 100804 V	=	MH 080	+	BFS MH 1
B 100806 H	=	MH 122	+	BFS MH 1
B 100806 V	=	MH 080	+	BFS MH 1
B 100809 H	=	MH 122	+	BFS MH 1
B 100809 V	=	MH 080	+	BFS MH 1
B 140804 H	=	MH 167	+	BFS MH 1
B 140804 V	=	MH 080	+	BFS MH 1
B 140806 H	=	MH 167	+	BFS MH 1
B 140806 V	=	MH 080	+	BFS MH 1
B 140809 H	=	MH 167	+	BFS MH 1
B 140809 V	=	MH 080	+	BFS MH 1
B 141304 H	=	MH 167	+	BFS MH 1
B 141304 V	=	MH 122	+	BFS MH 1
B 141306 H	=	MH 167	+	BFS MH 1
B 141306 V	=	MH 122	+	BFS MH 1
B 141309 H	=	MH 167	+	BFS MH 1
B 141309 V	=	MH 122	+	BFS MH 1
B 180804 H	=	MH 220	+	BFS MH 1
B 180804 V	=	MH 080	+	BFS MH 1
B 180806 H	=	MH 220	+	BFS MH 1
B 180806 V	=	MH 080	+	BFS MH 1
B 180809 H	=	MH 220	+	BFS MH 1
B 180809 V	=	MH 080	+	BFS MH 1
B 181304 H	=	MH 220	+	BFS MH 1
B 181304 V	=	MH 122	+	BFS MH 1
B 181306 H	=	MH 220	+	BFS MH 1
B 181306 V	=	MH 122	+	BFS MH 1
B 181309 H	=	MH 220	+	BFS MH 1
B 181309 V	=	MH 122	+	BFS MH 1
B 221304 H	=	MH 220	+	BFS MH 1
B 221304 V	=	MH 122	+	BFS MH 1
B 221306 H	=	MH 220	+	BFS MH 1
B 221306 V	=	MH 122	+	BFS MH 1
B 221309 H	=	MH 220	+	BFS MH 1
B 221309 V	=	MH 122	+	BFS MH 1
B 233012 V	=	MH 220	+	BFS MH 2
B 233016 V	=	MH 220	+	BFS MH 2
B 261306 H	=	MH 265	+	BFS MH 1
B 261306 V	=	MH 122	+	BFS MH 1
B 261704 H	=	MH 265	+	BFS MH 1
B 261704 V	=	MH 167	+	BFS MH 1
B 261706 H	=	MH 265	+	BFS MH 1
B 261706 V	=	MH 167	+	BFS MH 1
B 261709 H	=	MH 265	+	BFS MH 1
B 261709 V	=	MH 167	+	BFS MH 1
B 261712 H	=	MH 265	+	BFS MH 1
B 261712 V	=	MH 167	+	BFS MH 1
B 273612 V	=	MH 265	+	BFS MH 2
B 273616 V	=	MH 265	+	BFS MH 2

H = horizontal



V = vertical



Verwendung der Mastbefestigung für Bocube Alu
Use of the mast attachment for Bocube Alu

Bitte wählen Sie anhand dieser Tabelle je nach Größe und Ausrichtung des Gehäuses die passende Mastbefestigung und den dazugehörigen Befestigungssatz aus.

Please use this table to select the appropriate mast mounting and the associated mounting kit, depending on the size and alignment of the enclosure.

Ausrichtung des Gehäuses / Alignment of the enclosure :

H = horizontal

V = vertical

Gehäuse Enclosure		Mastbefestigung Mast bracket		Befestigungssatz Mounting kit
BA 100806 V	=	MH 080	+	BFS MH 2
BA 140806 H	=	MH 167	+	BFS MH 2
BA 140806 V	=	MH 080	+	BFS MH 2
BA 141306 H	=	MH 167	+	BFS MH 2
BA 141306 V	=	MH 122	+	BFS MH 2
BA 141309 H	=	MH 167	+	BFS MH 2
BA 141309 V	=	MH 122	+	BFS MH 2
BA 180806 H	=	MH 220	+	BFS MH 2
BA 180806 V	=	MH 080	+	BFS MH 2
BA 180809 H	=	MH 220	+	BFS MH 2
BA 180809 V	=	MH 080	+	BFS MH 2
BA 241306 H	=	MH 265	+	BFS MH 2
BA 241306 V	=	MH 122	+	BFS MH 2
BA 241309 H	=	MH 265	+	BFS MH 2
BA 241309 V	=	MH 122	+	BFS MH 2
BA 281706 V	=	MH 167	+	BFS MH 2
BA 281709 V	=	MH 167	+	BFS MH 2

H = horizontal



V = vertical



Verwendung der Mastbefestigung für Euromas ABS / PC
Use of the mast attachment for Euromas ABS / PC

Bitte wählen Sie anhand dieser Tabelle je nach Größe und Ausrichtung des Gehäuses die passende Mastbefestigung und den dazugehörigen Befestigungssatz aus.

Please use this table to select the appropriate mast mounting and the associated mounting kit, depending on the size and alignment of the enclosure.

Ausrichtung des Gehäuses / Alignment of the enclosure:

H = horizontal

V = vertical

Gehäuse Enclosure		Mastbefestigung Mast bracket		Befestigungssatz Mounting kit
M/T 210 H	=	MH 080	+	BFS MH 1
M/T 210 V	=	MH 080	+	BFS MH 1
M/T 215 H	=	MH 122	+	BFS MH 1
M/T 215 V	=	MH 080	+	BFS MH 1
M/T 216 H	=	MH 122	+	BFS MH 1
M/T 216 V	=	MH 080	+	BFS MH 1
M/T 217 V/H	=	MH 122	+	BFS MH 1
M/T 219 H	=	MH 167	+	BFS MH 1
M/T 219 V	=	MH 080	+	BFS MH 1
M/T 220 H	=	MH 167	+	BFS MH 1
M/T 220 V	=	MH 080	+	BFS MH 1
M/T 221 H	=	MH 220	+	BFS MH 1
M/T 221 V	=	MH 122	+	BFS MH 1
M/T 223 H	=	MH 220	+	BFS MH 1
M/T 223 V	=	MH 167	+	BFS MH 1
M/T 225 H	=	MH 080	+	BFS MH 1
M/T 225 V	=	MH 080	+	BFS MH 1
M/T 226 H	=	MH 122	+	BFS MH 1
M/T 226 V	=	MH 080	+	BFS MH 1
M/T 227 V/H	=	MH 122	+	BFS MH 1
M/T 228 V/H	=	MH 122	+	BFS MH 1
M/T 230 H	=	MH 122	+	BFS MH 1
M/T 230 V	=	MH 080	+	BFS MH 1
M/T 231 H	=	MH 167	+	BFS MH 1
M/T 231 V	=	MH 080	+	BFS MH 1
M/T 235 H	=	MH 167	+	BFS MH 1
M/T 235 V	=	MH 080	+	BFS MH 1
M/T 237 H	=	MH 220	+	BFS MH 1
M/T 237 V	=	MH 122	+	BFS MH 1
M/T 238 H	=	MH 167	+	BFS MH 1
M/T 238 V	=	MH 122	+	BFS MH 1
M/T 2381 H	=	MH 167	+	BFS MH 1
M/T 2381 V	=	MH 122	+	BFS MH 1
M/T 240 H	=	MH 265	+	BFS MH 1
M/T 240 V	=	MH 167	+	BFS MH 1
M/T 2401 H	=	MH 265	+	BFS MH 1
M/T 2401 V	=	MH 167	+	BFS MH 1
M/T 241 H	=	MH 265	+	BFS MH 1
M/T 241 V	=	MH 167	+	BFS MH 1
M/T 242 H	=	MH 265	+	BFS MH 1
M/T 242 V	=	MH 122	+	BFS MH 1
M/T 243 H	=	MH 265	+	BFS MH 1
M/T 243 V	=	MH 167	+	BFS MH 1
M/T 246 H	=	MH 167	+	BFS MH 1
M/T 246 V	=	MH 122	+	BFS MH 1
M/T 250 H	=	MH 265	+	BFS MH 1
M/T 250 V	=	MH 167	+	BFS MH 1
M/T 251 V	=	MH 167	+	BFS MH 1
M/T 252 V	=	MH 220	+	BFS MH 1
M/T 253 V	=	MH 220	+	BFS MH 1
M/T 254 V	=	MH 220	+	BFS MH 1

H = horizontal



V = vertical



Bitte wählen Sie anhand dieser Tabelle je nach Größe und Ausrichtung des Gehäuses die passende Mastbefestigung und den dazugehörigen Befestigungssatz aus.

Please use this table to select the appropriate mast mounting and the associated mounting kit, depending on the size and alignment of the enclosure.

Ausrichtung des Gehäuses / Alignment of the enclosure:

H = horizontal

V = vertical

Gehäuse Enclosure		Mastbefestigung Mast bracket		Befestigungssatz Mounting kit
EM/ET 210 H	=	MH 080	+	BFS MH 1
EM/ET 210 V	=	MH 080	+	BFS MH 1
EM/ET 212 H	=	MH 122	+	BFS MH 1
EM/ET 212 V	=	MH 080	+	BFS MH 1
EM/ET 213 V/H	=	MH 122	+	BFS MH 1
EM/ET 214-LP H	=	MH 220	+	BFS MH 1
EM/ET 214-LP V	=	MH 122	+	BFS MH 1
EM/ET 215 H	=	MH 122	+	BFS MH 1
EM/ET 215 V	=	MH 080	+	BFS MH 1
EM/ET 217 V/H	=	MH 122	+	BFS MH 1
EM/ET 218-LP H	=	MH 167	+	BFS MH 1
EM/ET 218-LP V	=	MH 167	+	BFS MH 1
EM/ET 220 H	=	MH 167	+	BFS MH 1
EM/ET 220 V	=	MH 080	+	BFS MH 1
EM/ET 221 H	=	MH 220	+	BFS MH 1
EM/ET 221 V	=	MH 122	+	BFS MH 1
EM/ET 223 H	=	MH 220	+	BFS MH 1
EM/ET 223 V	=	MH 167	+	BFS MH 1
EM/ET 224 H	=	MH 265	+	BFS MH 1
EM/ET 224 V	=	MH 080	+	BFS MH 1
EM/ET 225 H	=	MH 080	+	BFS MH 1
EM/ET 225 V	=	MH 080	+	BFS MH 1
EM/ET 227 V	=	MH 122	+	BFS MH 1
EM/ET 229 H	=	MH 167	+	BFS MH 1
EM/ET 229 V	=	MH 080	+	BFS MH 1
EM/ET 231 H	=	MH 167	+	BFS MH 1
EM/ET 231 V	=	MH 080	+	BFS MH 1
EM/ET 232 H	=	MH 220	+	BFS MH 1
EM/ET 232 V	=	MH 167	+	BFS MH 1
EM/ET 233 V	=	MH 167	+	BFS MH 1
EM/ET 236-LP H	=	MH 265	+	BFS MH 1
EM/ET 236-LP V	=	MH 080	+	BFS MH 1
EM/ET 237 H	=	MH 220	+	BFS MH 1
EM/ET 237 V	=	MH 122	+	BFS MH 1
EM/ET 238 H	=	MH 167	+	BFS MH 1
EM/ET 238 V	=	MH 122	+	BFS MH 1
EM/ET 239 H	=	MH 265	+	BFS MH 1
EM/ET 239 V	=	MH 167	+	BFS MH 1
EM/ET 240 H	=	MH 265	+	BFS MH 1
EM/ET 240 V	=	MH 167	+	BFS MH 1
EM/ET 241 H	=	MH 265	+	BFS MH 1
EM/ET 241 V	=	MH 167	+	BFS MH 1
EM/ET 242 H	=	MH 265	+	BFS MH 1
EM/ET 242 V	=	MH 122	+	BFS MH 1
EM/ET 247 V	=	MH 167	+	BFS MH 1

H = horizontal



V = vertical



Verwendung der Mastbefestigung für Euromas Aluminium Use of the mast attachment for Euromas Aluminium

Bitte wählen Sie anhand dieser Tabelle je nach Größe und Ausrichtung des Gehäuses die passende Mastbefestigung und den dazugehörigen Befestigungssatz aus.

Please use this table to select the appropriate mast mounting and the associated mounting kit, depending on the size and alignment of the enclosure.

Ausrichtung des Gehäuses / Alignment of the enclosure:

H = horizontal

V = vertical

Gehäuse Enclosure		Mastbefestigung Mast bracket		Befestigungssatz Mounting kit
A 114 H	=	MH 220	+	BFS MH 1
A 114 V	=	MH 080	+	BFS MH 1
A 116 V	=	MH 080	+	BFS MH 1
A 118 H	=	MH 167	+	BFS MH 1
A 118 V	=	MH 080	+	BFS MH 1
A 119 H	=	MH 122	+	BFS MH 3
A 119 V	=	MH 122	+	BFS MH 3
A 120 H	=	MH 122	+	BFS MH 3
A 120 V	=	MH 122	+	BFS MH 3
A 121 H	=	MH 167	+	BFS MH 3
A 122 H	=	MH 220	+	BFS MH 3
A 122 V	=	MH 122	+	BFS MH 3
A 123 H	=	MH 220	+	BFS MH 3
A 123 V	=	MH 122	+	BFS MH 3
A 124 V	=	MH 122	+	BFS MH 3
A 125 H	=	MH 167	+	BFS MH 3
A 125 V	=	MH 122	+	BFS MH 3
A 126 H	=	MH 220	+	BFS MH 3
A 127 H	=	MH 220	+	BFS MH 3
A 127 V	=	MH 167	+	BFS MH 3
A 130 H	=	MH 265	+	BFS MH 3
A 130 V	=	MH 122	+	BFS MH 3
A 131 V	=	MH 167	+	BFS MH 3
A 135 V	=	MH 122	+	BFS MH 3
A 138 V	=	MH 122	+	BFS MH 3
A 140 V/H	=	MH 220	+	BFS MH 3
A 145 H	=	MH 220	+	BFS MH 3
A 145 V	=	MH 122	+	BFS MH 3
A 150 V/H	=	MH 220	+	BFS MH 3
A 155 V	=	MH 220	+	BFS MH 3
A 160 V	=	MH 220	+	BFS MH 3
A 165 V	=	MH 220	+	BFS MH 3
A 168 V	=	MH 220	+	BFS MH 3
A 169 V	=	MH 220	+	BFS MH 3
A 170 V	=	MH 220	+	BFS MH 3

H = horizontal



V = vertical



Verwendung der Mastbefestigung für Euromas Polyester Use of the mast attachment for Euromas Polyester

Bitte wählen Sie anhand dieser Tabelle je nach Größe und Ausrichtung des Gehäuses die passende Mastbefestigung und den dazugehörigen Befestigungssatz aus.

Please use this table to select the appropriate mast mounting and the associated mounting kit, depending on the size and alignment of the enclosure.

Ausrichtung des Gehäuses / Alignment of the enclosure:

H = horizontal

V = vertical

Gehäuse Enclosure		Mastbefestigung Mast bracket		Befestigungssatz Mounting kit
P 305 H	=	MH 080	+	BFS MH 1
P 305 V	=	MH 080	+	BFS MH 1
P 311 V	=	MH 080	+	BFS MH 1
P 316 H	=	MH 167	+	BFS MH 1
P 316 V	=	MH 080	+	BFS MH 1
P 319 H	=	MH 220	+	BFS MH 1
P 319 V	=	MH 080	+	BFS MH 1
P 322 H	=	MH 265	+	BFS MH 1
P 322 V	=	MH 080	+	BFS MH 1
P 324 V	=	MH 080	+	BFS MH 1
P 325 H	=	MH 167	+	BFS MH 1
P 325 V	=	MH 080	+	BFS MH 1
P 326 H	=	MH 080	+	BFS MH 1
P 326 V	=	MH 080	+	BFS MH 1
P 327 H	=	MH 265	+	BFS MH 1
P 327 V	=	MH 080	+	BFS MH 1
P 329 H	=	MH 220	+	BFS MH 1
P 329 V	=	MH 080	+	BFS MH 1
P 330 H	=	MH 167	+	BFS MH 1
P 330 V	=	MH 122	+	BFS MH 3
P 331 V	=	MH 122	+	BFS MH 3
P 332 H	=	MH 122	+	BFS MH 3
P 332 V	=	MH 122	+	BFS MH 3
P 333 H	=	MH 265	+	BFS MH 3
P 333 V	=	MH 122	+	BFS MH 3
P 334 V	=	MH 122	+	BFS MH 3
P 336 V	=	MH 080	+	BFS MH 3
P 337 H	=	MH 265	+	BFS MH 3
P 337 V	=	MH 220	+	BFS MH 3
P 338 H	=	MH 265	+	BFS MH 3
P 338 V	=	MH 220	+	BFS MH 3
P 340 V	=	MH 220	+	BFS MH 3
P 342 V	=	MH 220	+	BFS MH 3
P 345 V	=	MH 122	+	BFS MH 3
P 355 V	=	MH 220	+	BFS MH 3

H = horizontal



V = vertical



MH Masthalterung / Verwendung:

Auswahl nach Befestigungsabstand für andere Gehäuse:

Befestigungsabstand	Schrauben	Masthalter
45-50	für ø4mm	MH 080
62-66	für ø5mm	MH 080
68-70	für ø5mm	MH 080
80-82	für ø5mm	MH 122
88-90	für ø4mm	MH 122
106-108	für ø5mm	MH 122
110	für ø5mm	MH 122
119-120	für ø5mm	MH 167
127-130	für ø5mm	MH 167
138-140	für ø5mm	MH 167
146-148	für ø5mm	MH 167
152-153	für ø5mm	MH 167
160	für ø5mm	MH 220
167	für ø5mm	MH 220
178-180	für ø5mm	MH 220
186-188	für ø4mm	MH 220
200	für ø5mm	MH 220
204-206	für ø5mm	MH 220
218	für ø4mm	MH 265
228-229	für ø5mm	MH 265
235-240	für ø5mm	MH 265
247-251	für ø5mm	MH 265

aus dem Polysafe-Programm:

155	für ø6mm	PS MH-030
223	für ø6mm	PS MH-030
245	für ø6mm	PS MH-030
273	für ø6mm	PS MH-030
335	für ø6mm	PS MH-040
373	für ø6mm	PS MH-040
473	für ø6mm	PS MH-050
515	für ø6mm	PS MH-060
573	für ø6mm	PS MH-060

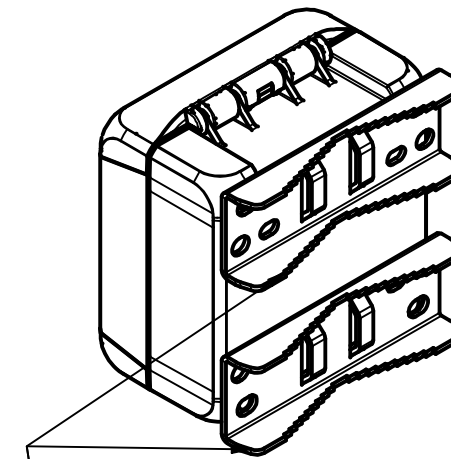
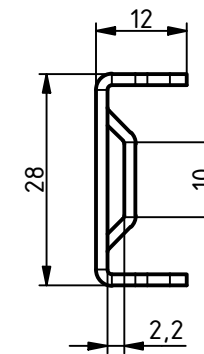
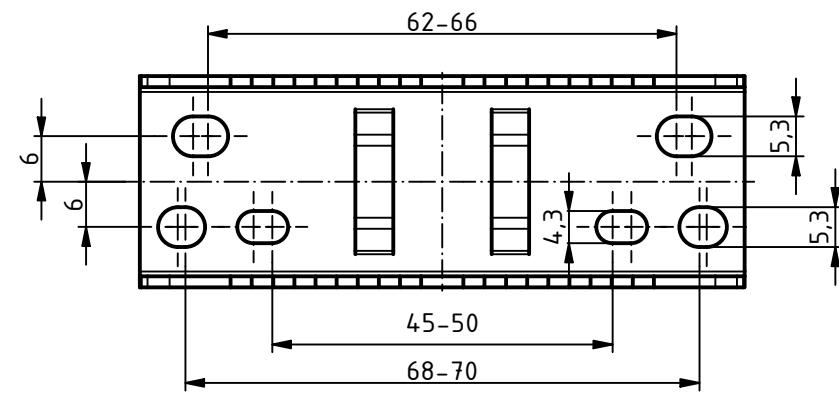

1 Satz MH 080 bestehend aus 2 St. Blechwinkel.
Zur Montage der Masthalterung an ein Gehäuseunterteil
müssen die Schraubensätze separat bestellt werden.

1 set MH 080 consisting of 2 sheet metal brackets.
For mounting the mast bracket to a enclosure base
the screw sets have to be ordered separately.

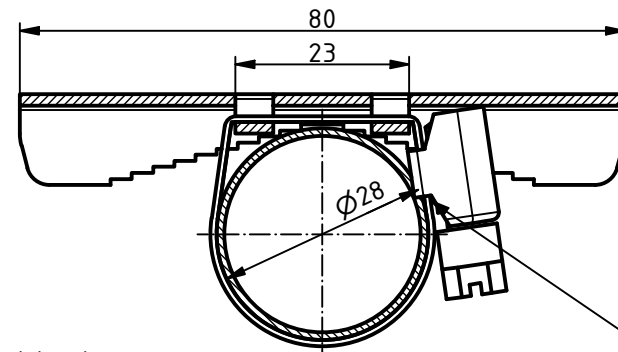

Minimaler Mastdurchmesser
min. Mast Diameter

Befestigungsschelle / Kabelbinder
(nicht im Lieferumfang)
*Fastening clip / cable clamp
(not included in the scope of delivery)*

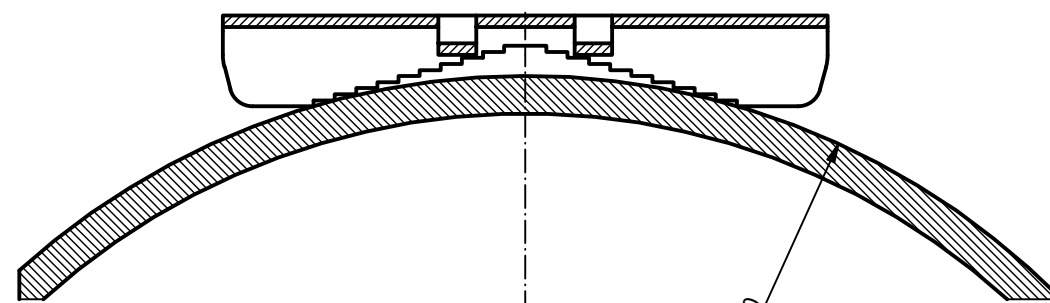

Maximaler Mastdurchmesser
max. Mast Diameter

Maßstab/ Scale: 1:1 (1:2)

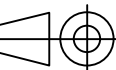

Zeichnungs-Nr. / Drawing-No.:
3K 5390.338.01

Artikel / Article:
MH 080
Katalogzeichnung

Ä.Nr/
Alt.No:

Datum/
Date:



DISK: 2504504.idw
Datum/Date: 23.03.2021 KH

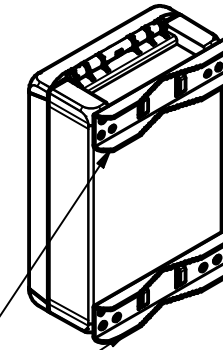
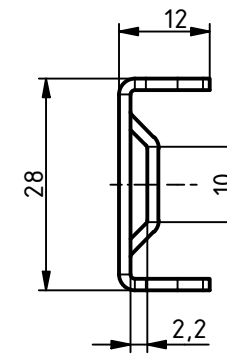
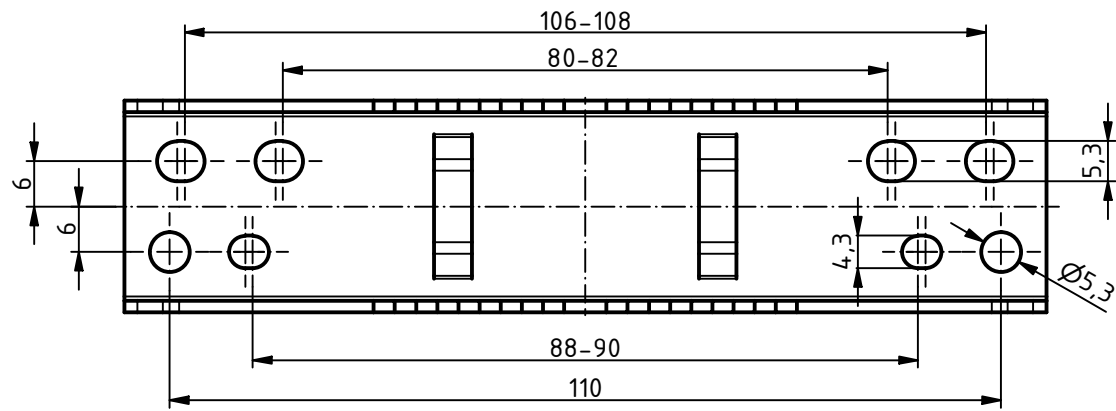

1 Satz MH 122 bestehend aus 2 St. Blechwinkel.
Zur Montage der Masthalterung an ein Gehäuseunterteil
müssen die Schraubensätze separat bestellt werden.

1 set MH 122 consisting of 2 sheet metal brackets.
For mounting the mast bracket to a enclosure base
the screw sets have to be ordered separately.

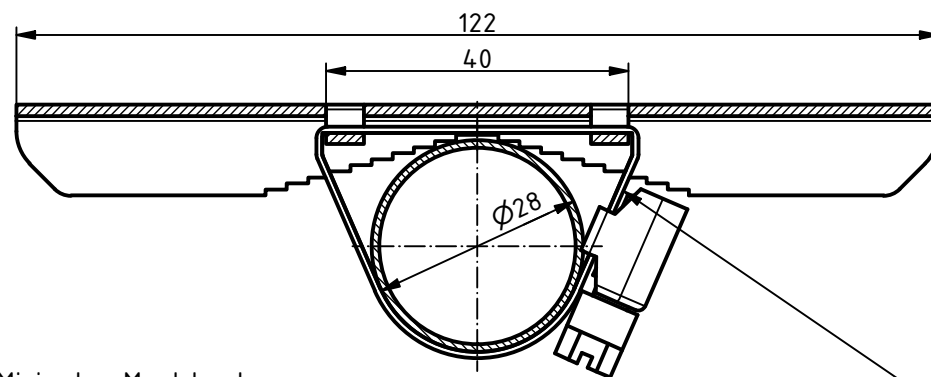

Befestigungsschelle / Kabelbinder
(nicht im Lieferumfang)
Fastening clip / cable clamp
(not included in the scope of delivery)

Minimaler Mastdurchmesser
min. Mast Diameter

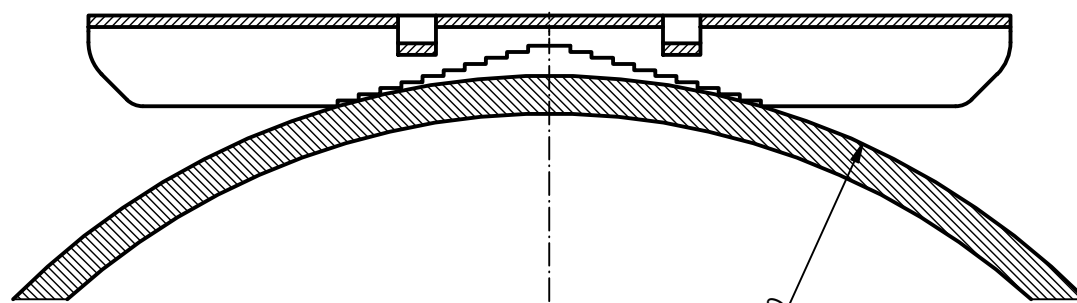

Maximaler Mastdurchmesser
max. Mast Diameter

Maßstab/ Scale: 1:1 (1:5)

Zeichnungs-Nr. / Drawing-No.:
3K 5390.339.01

Artikel / Article:
MH 122
Katalogzeichnung

Ä.Nr/ Alt.No:	Datum/ Date:	 BOPLA A Phoenix Mecano Company
DISK: 2504505.idw Datum/Date: 23.03.2021 KH		

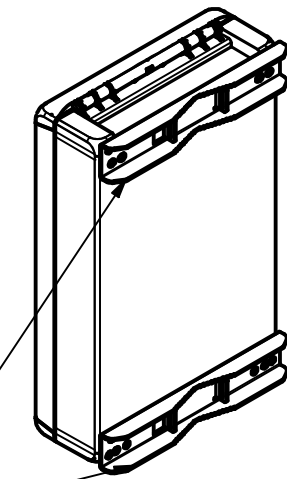
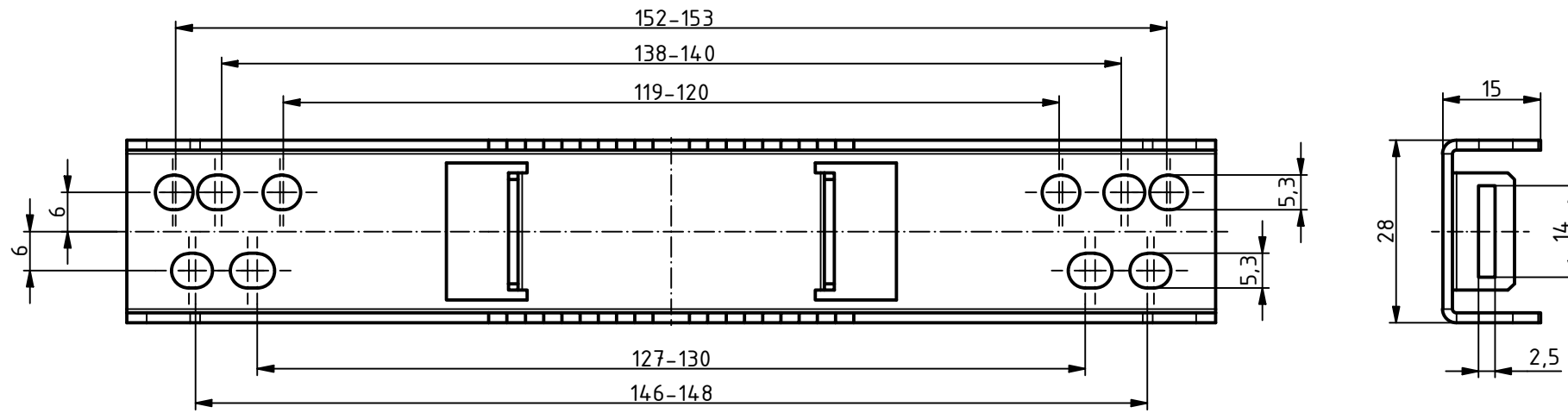

1 Satz MH 167 bestehend aus 2 St. Blechwinkel.
Zur Montage der Masthalterung an ein Gehäuseunterteil
müssen die Schraubensätze separat bestellt werden.

1 set MH 167 consisting of 2 sheet metal brackets.
For mounting the mast bracket to a enclosure base
the screw sets have to be ordered separately.

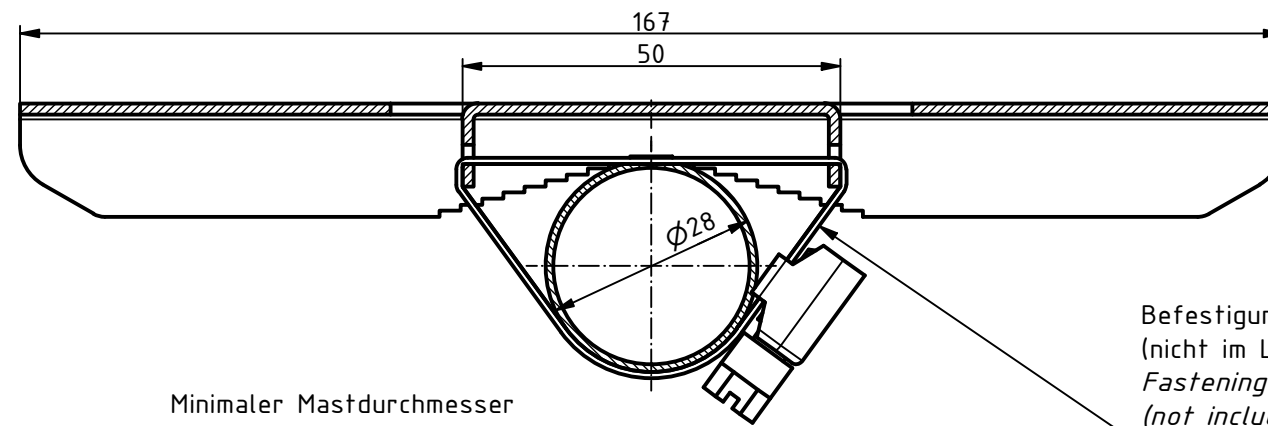

Minimaler Mastdurchmesser
min. Mast Diameter

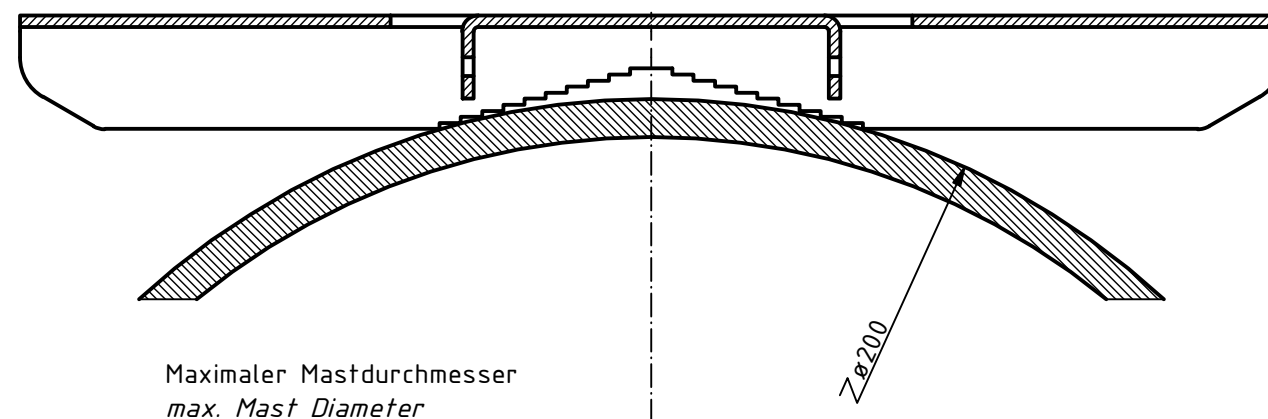

Maximaler Mastdurchmesser
max. Mast Diameter

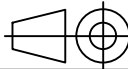
Maßstab/ Scale: 1:1 (1:5) 

Zeichnungs-Nr. / Drawing-No.: 3K 5390.340.01

Artikel / Article: MH 167
Katalogzeichnung

Ä.Nr/ Alt.No:	Datum/ Date:	 BOPLA A Phoenix Mecano Company
DISK:	2504506.idw	

Datum/Date: 23.03.2021 KH

"Schutzvermerk nach DIN ISO 16016 beachten" "Please pay attention to copyright note DIN ISO 16016"

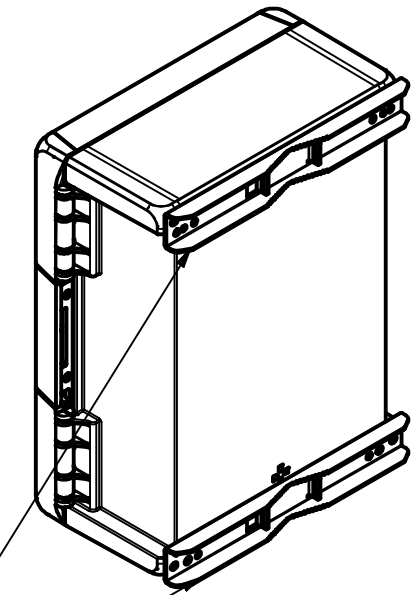
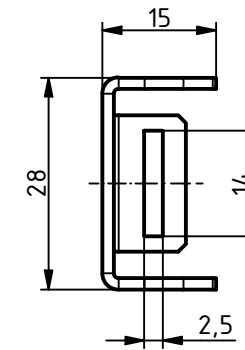
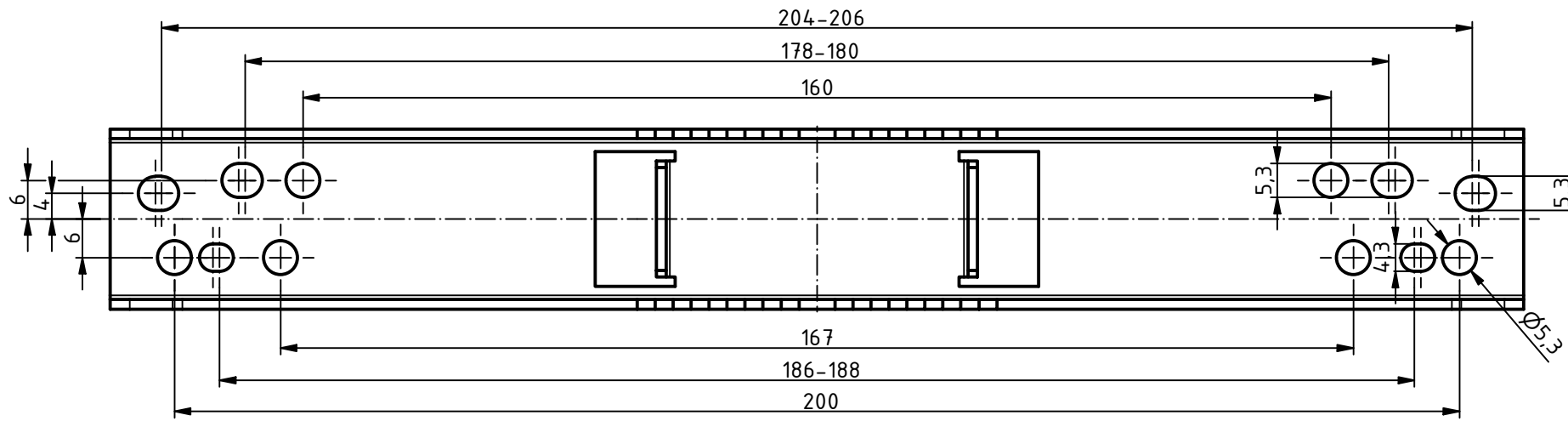

1 Satz MH 220 bestehend aus 2 St. Blechwinkel.
Zur Montage der Masthalterung an ein Gehäuseunterteil
müssen die Schraubensätze separat bestellt werden.

1 set MH 220 consisting of 2 sheet metal brackets.
For mounting the mast bracket to a enclosure base
the screw sets have to be ordered separately.

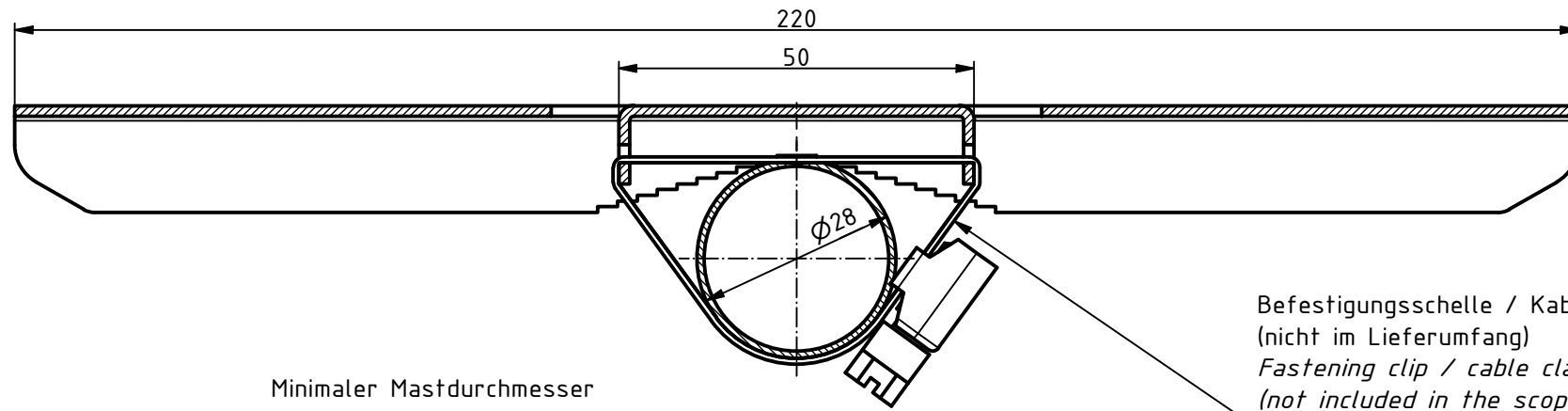

Befestigungsschelle / Kabelbinder
(nicht im Lieferumfang)
Fastening clip / cable clamp
(not included in the scope of delivery)

Minimaler Mastdurchmesser
min. Mast Diameter

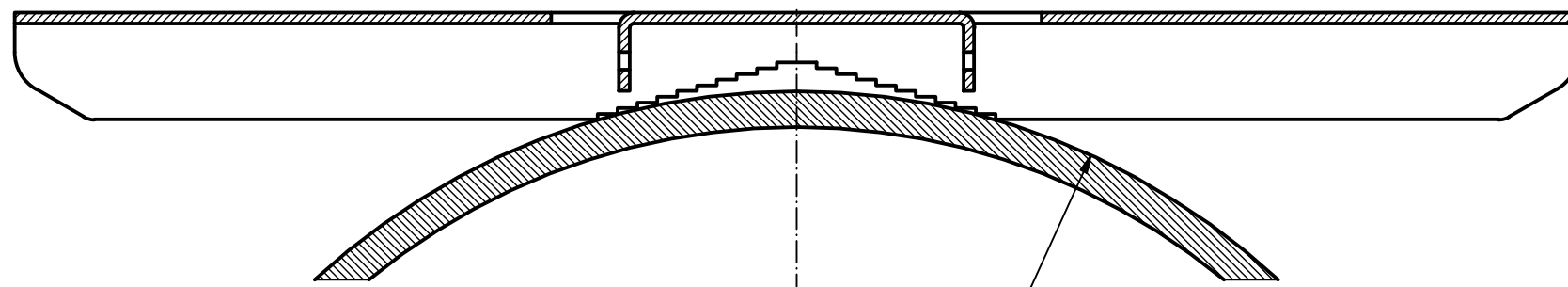

Maximaler Mastdurchmesser
max. Mast Diameter

Maßstab/ Scale: 1:1 (1:5)

Zeichnungs-Nr. / Drawing-No.:
3K 5390.341.01

Artikel / Article:
MH 220
Katalogzeichnung

Ä.Nr/ Alt.No:	Datum/ Date:	BOPLA <small>A Phoenix Mecano Company</small>
DISK: 2504507.idw Datum/Date: 23.03.2021 KH		

"Schutzvermerk nach DIN ISO 16016 beachten" "Please pay attention to copyright note DIN ISO 16016"

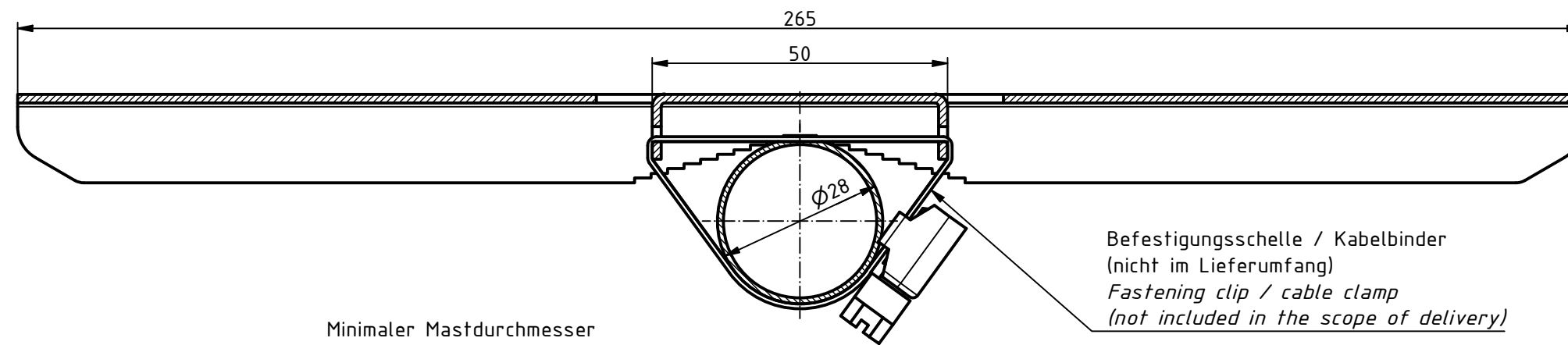
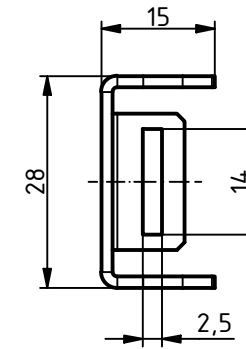
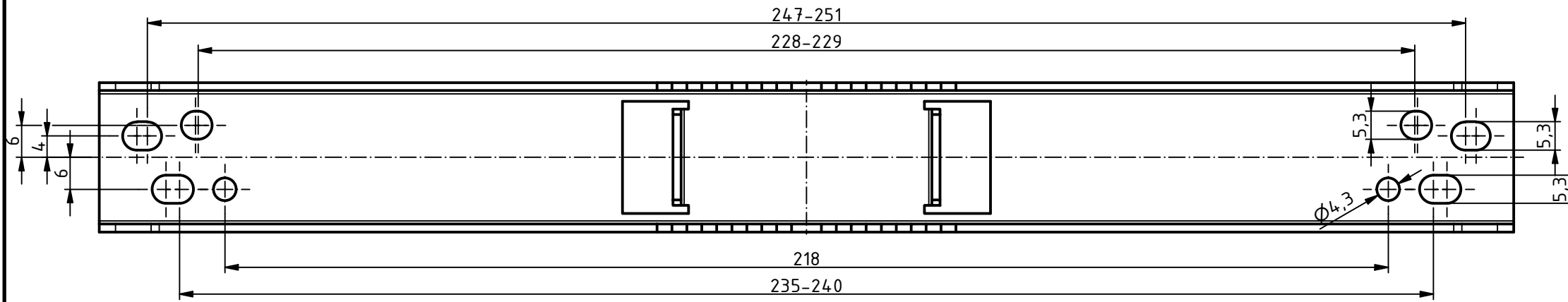

Minimaler Mastdurchmesser
min. Mast Diameter

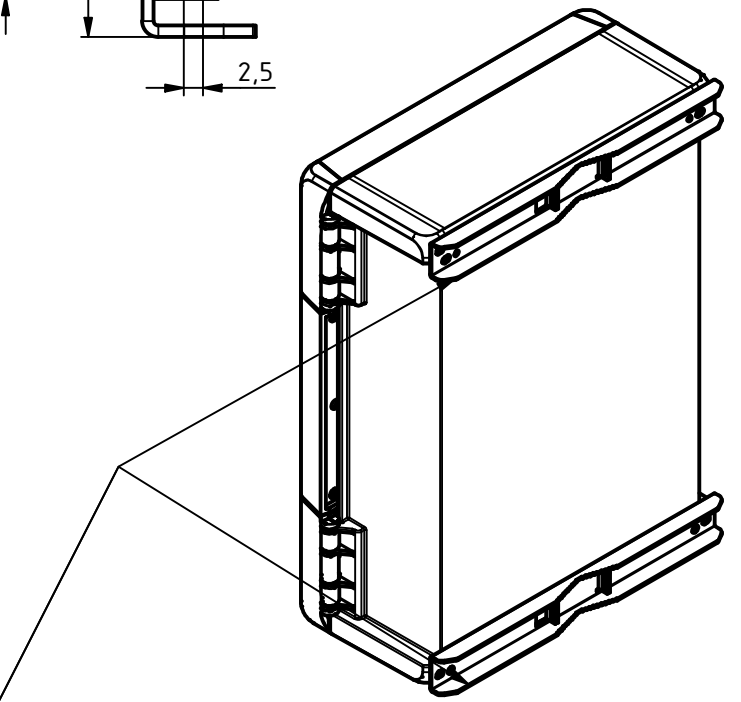

1 Satz MH 265 bestehend aus 2 St. Blechwinkel.
Zur Montage der Masthalterung an ein Gehäuseunterteil
müssen die Schraubensätze separat bestellt werden.

1 set MH 265 consisting of 2 sheet metal brackets.
For mounting the mast bracket to a enclosure base
the screw sets have to be ordered separately.

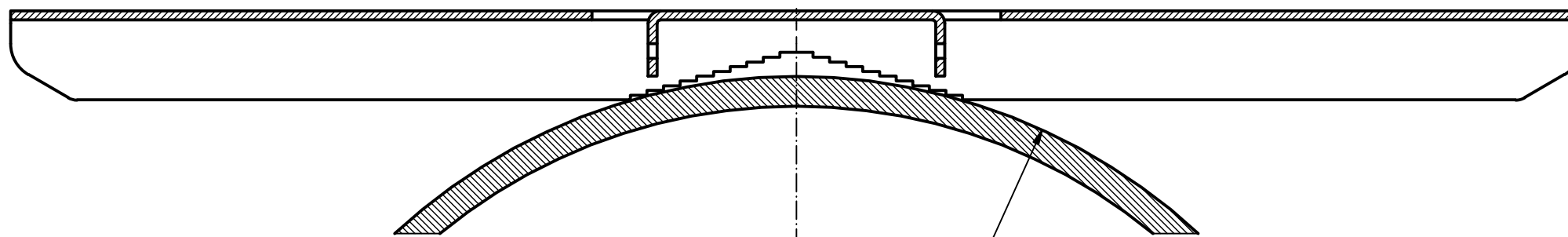

Maximaler Mastdurchmesser
max. Mast Diameter

Maßstab/ Scale: 1:1 (1:5)

Zeichnungs-Nr. / Drawing-No.: 2K 5390.342.01

Artikel / Article: MH 265
Katalogzeichnung

Ä.Nr/ Alt.No:	Datum/ Date:	BOPLA <small>A Phoenix Mecano Company</small>
DISK: 2504508.idw Datum/Date: 23.03.2021 KH		